

4000 Series IP Connectivity / Networking Guide

Includes instructions for Ethernet Adapters, WiFi Adapters and Barrett 4000 Series HF Remote Control app

BCM40507/07

(For s/w v1.7.0 and above)

© Barrett Communications

Contents

INTRODUCTION 1	5
Guide Overview	6
Terms and Abbreviations	7
The Barrett WiFi Adaptors	9
Connection Details	10
4050	10
4050/4090 Control handset	12
4090 SDS	13
WIRELESS SET-UP SCENARIOS 2	15
Connecting the WiFi Adaptor to the Transceiver	16
Setting up the Transceiver as a WiFi Access Point.....	16
WPS Push Button	18
Connecting	19
SCENARIO 1 - WiFi Access Point Setup with Windows/iOS/Android Devices	20
For Windows PCs	20
For iOS Devices	22
For Android Devices	23
Using the Barrett 4000 Series HF Remote Control App	24
SCENARIO 2 - WiFi Client Mode.....	27
Setting up the transceiver as WiFi Client.....	28
Setting up the PC.....	30

ETHERNET SET-UP SCENARIOS 3	31
SCENARIO 3 - Ethernet/Switch/PC.....	32
SCENARIO 4 - Ethernet/Switch/DHCP Server/PC	41
SCENARIO 5 - Ethernet Adapter/Router (VPN)/Internet/Router/PC.....	46
APPENDICES 4	51
APPENDIX 1 - Recommended Network Specifications	52
APPENDIX 2 - Setting up DHCP on Windows 10 Professional	53
APPENDIX 3 - Setting up Port Forwarding in your Router.....	56
APPENDIX 4 - Allowing Ports with a Firewall on Windows 10 Professional..	58
APPENDIX 5 - Setting up a VPN	60
APPENDIX 6 - Finding your Transceiver’s IP Address	64
APPENDIX 7 - Troubleshooting	65
Warranty Statement.....	66
Contact Details.....	68

INTRODUCTION 1

This chapter contains the following sections:

- Guide Overview
- Terms and Abbreviations
- The Barrett WiFi Adaptor
- Connection Details

Guide Overview

Barrett 4000 Series HF SDR transceivers can interface with:

- RJ45 Ethernet cable (PREFERRED)
- WiFi Adapter (P/N BCO40508)
- USB to Ethernet Adaptor (P/N BCA40505)
- 4050 to USB Adaptor (P/N BCA40502)
- 4050 to Ethernet Adaptor (P/N BCA40503)
- 4050 to Ethernet Adaptor with USB Ports (P/N BCA40504)

Chapter 1 offers definitions and hardware descriptions.

Chapters 2 and 3 provide examples of typical setup scenarios of a transceiver, network access and/or a computer. Each set-up may need to be configured differently in accordance with local network operating procedures and security.

Chapter 2 demonstrates how to set up the transceiver wirelessly. Scenario 1 outlines the different applications (apps) that can be used on Windows, iOS, and Android software. Scenario 2, however, connects over local WiFi via a router.

Chapter 3 demonstrates four ways of connecting the internet and transceiver via an Ethernet connection. Scenarios 3 and 4 show how a system could be set up using a small local area network. This allows multiple operators on the local area network to control or program the transceiver remotely. These scenarios show a configuration using a switch and a computer with and without a DHCP server. Scenario 3 is set up using a static IP address via an Ethernet cable, and the transceiver in the fourth scenario uses DHCP protocols.

Scenario 5 shows how to configure a transceiver over the internet via a VPN which provides added security. The benefit of this set up is that the operator can be outside the LAN, and have access to the transceiver.

Chapter 4 contains the appendices with additional information on DHCP, port forwarding and VPNs.

The scenarios given throughout the manual are using Windows 10 Professional as the operating system. Support can be provided for other Windows operating systems, ask your network administrator or your dealer for more information.

It is recommended that wherever possible, an Ethernet connection be used for IP connection.

Terms and Abbreviations

Term	Definition
Bonjour	Bonjour is Apple's implementation of zero-configuration networking, a group of technologies that includes service discovery, address assignment, and host name resolution.
DHCP	Dynamic Host Configuration Protocol
DNS	Domain Name Servers are the Internet's equivalent of a phone book. They maintain a directory of domain names and translate them to Internet Protocol (IP) addresses
Firewall	A security protocol designed to prevent unauthorised access to a private network. Firewalls can be implemented as hardware or software.
LAN	Local Area Network, an example would be an office network.
Network Switch	A multi-port network bridge that uses hardware addresses to process and forward data.
Port Forwarding	Or port mapping is a name given to the combined technique of translating the address and/or port number of a data packet to a new destination, possibly accepting such packet(s) in a packet filter (firewall), then forwarding the packet according to the routing table.
Router	A networking device that forwards data packets between computer networks. It provides a wired link to the LAN, and a gateway to external networks, for example the Internet.
Static IP Address	A manually configured IP address, sometimes referred to as a fixed IP address.
TCP	Transmission Control Protocol
UDP	User Datagram Protocol
VPN	A Virtual Private Network is a private network that extends across a public network or Internet and is usually secured at each end. It enables users to send and receive data across shared or public networks as if their computing devices were directly connected to the private network.
WAN	Wide Area Network, an example would be the Internet.

WiFi

Wireless Fidelity

WiFi Access Point
/ Router

Enables wireless network packet forwarding and routing, and serves as an access point in a local area network. It works much like a wired router but replaces wires with wireless radio signals to communicate within and provides a gateway to an external network (Internet).

The Barrett WiFi Adaptors

(P/N: BCO40508)



The WiFi Adaptors are necessary to connect the Barrett 4050 HF SDR Transceiver (P/N BC405000) via WiFi to external devices such as tablets, smart phones and PCs or to external networks. External devices can control the Barrett 4050 HF SDR Transceiver using the Barrett 4000 series Remote Control Software which is available for iOS, Android and Windows.

Two WiFi adaptors are supplied by Barrett. An Edimax adaptor for use with WiFi Access Point mode and a TP-Link adaptor for use with WiFi Client mode. Only one may be used at any time.

See [page 16](#) for examples of how to set up the Barrett 4050 HF SDR Transceiver to utilise WiFi.

Note: it is not possible to operate both the Wifi and Ethernet adapters simultaneously.

Connection Details

4050

This diagram represents all possible connections between a Barrett 4050se HF SDR Transceiver without an Ethernet socket on the rear panel and an IP network.

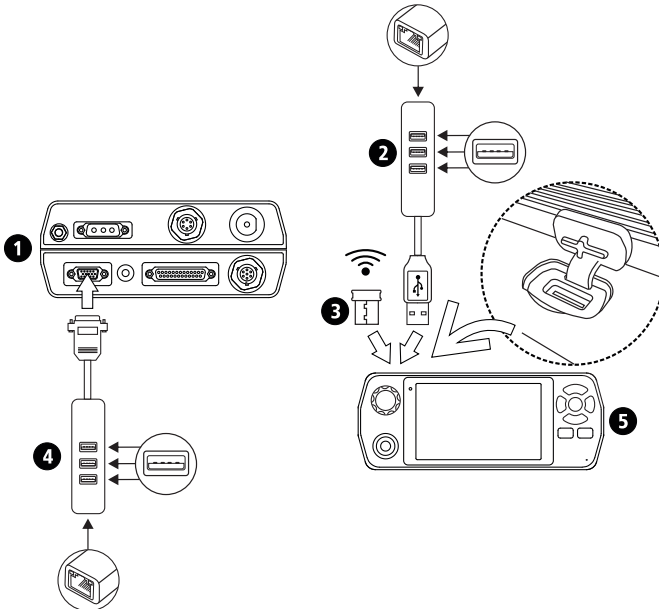

- 1 Barrett 4050se HF SDR Transceiver (rear) (P/N BC405000se)
- 2 USB to Ethernet Adaptor with USB ports (P/N BCA40505)
- 3 WiFi Adaptor (P/N BCO40508)
- 4 4050 to Ethernet Adaptor with USB ports (P/N BCA40504)
- 5 Barrett 4050 HF SDR Transceiver (front) (P/N BC405000)

Notes regarding USB connection via auxiliary controlhead (rear 15way):

- USB is available for 4050 transceivers with serial number 405010912 or newer and if there is no Ethernet port present at the back of the transceiver body
- The 6m controlhead extension cable P/N BCA40005 cannot be used at the same time with the USB/Ethernet adaptor P/N BCA40504. If the

6m extension cable is necessary and Ethernet connectivity is required then the only option is to use the USB/Ethernet adaptor P/N BCA40505 which connects into the top USB port of the controlhead.

This diagram represents the connection between a Barrett 4050ip HF SDR Transceiver with an Ethernet socket in the rear panel and an IP network.

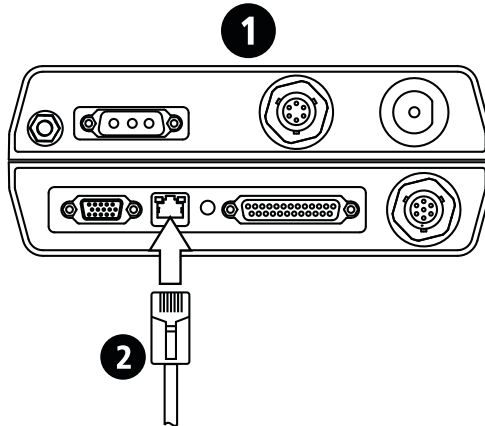

- 1 Barrett 4050ip HF SDR Transceiver (rear) (P/N BC405000ip)
- 2 Ethernet (RJ45) cable

4050/4090 Control handset

When using a 4050/4090 Control Handset without a docking station, a PRC-4090 Handset USB Interface (4090-01-27) must be attached to the rear of the handset.

The PRC-4090 Handset USB Interface is attached as shown in the diagrams below. Once in place, turn the wheel until unit is secure.

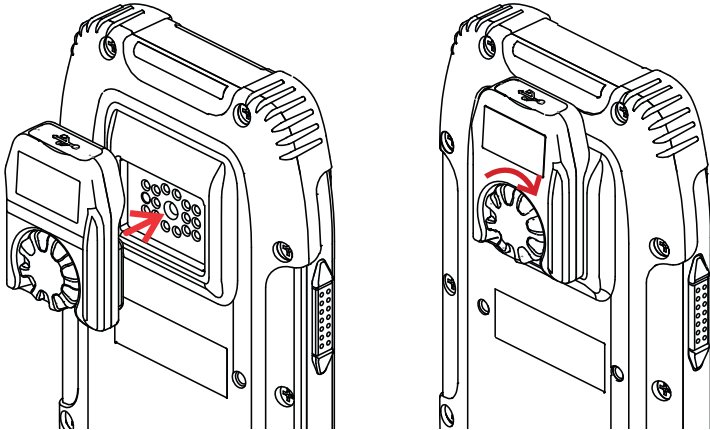

The below diagram shows the possible connections between the above 4050/4090 Control Handset and an IP network.

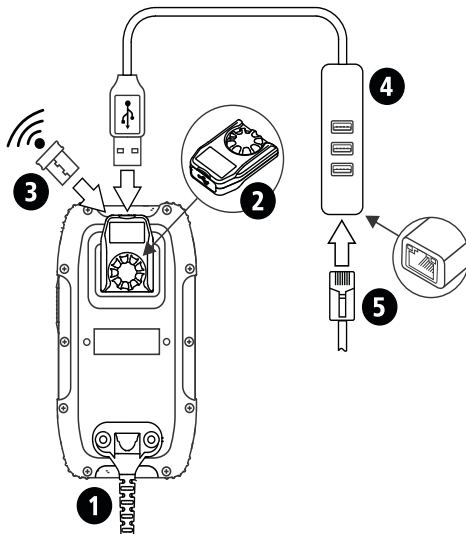

- 1 4050/4090 Control Handset (P/N BCA40500/4090-01-09)
- 2 PRC-4090 Handset USB Interface (4090-01-27)
- 3 WiFi Adaptor (P/N BCO40508)
- 4 USB to Ethernet Adaptor with USB ports (P/N BCA40505)
- 5 Ethernet (RJ45) cable

4090 SDS

The below diagram shows the network connection from a Barrett PRC-4090 HF SDR Transceiver in Mobile configuration (P/N 4091-00-10).

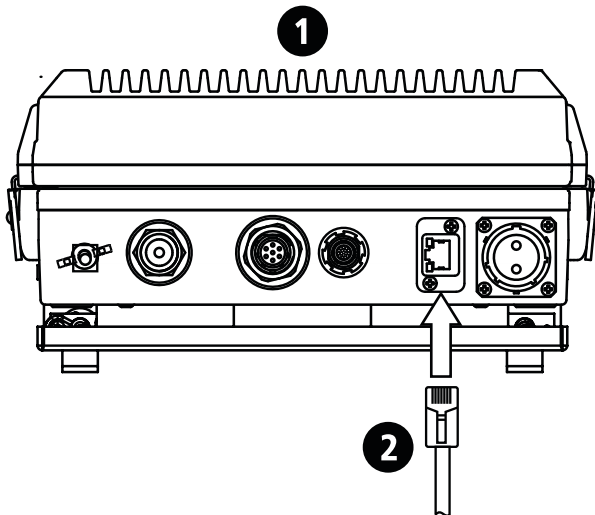

- 1 Barrett PRC-4090 HF SDR Transceiver in Mobile configuration (P/N 4091-00-10)
- 2 Ethernet (RJ45) cable

WIRELESS SET-UP SCENARIOS 2

This chapter contains the following sections:

- Connecting the WiFi Adaptor to the Transceiver
- Scenario 1 - WiFi Access Point set up for Windows, iOS and Android Devices
- Scenario 2 - WiFi Client Mode

Connecting the WiFi Adaptor to the Transceiver

Setting up the Transceiver as a WiFi Access Point

Prior to beginning the installation, ensure the **Edimax** WiFi adapter is inserted in the USB socket located on the top of the front panel of the transceiver or in the top of the Handset USB Interface on the Control Handset.

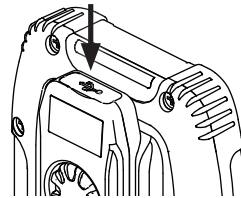

From the Barrett 4050 HF SDR Transceiver's Settings screen, tap **Network**  to display the Network Settings screen.

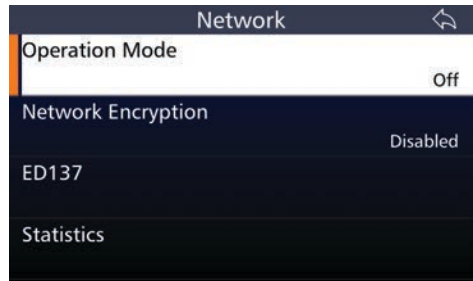

Tap **Operation Mode** from the Network Settings screen to display the Operation Mode screen. Select Access Point.

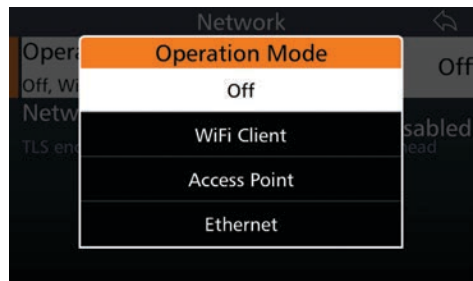

Tap **Configuration** from the Network Settings screen to display the WiFi Access Point screen.

The sub-menus are described below.



SSID

Tap **SSID** (Service Set Identifier) from the WiFi Access Point screen to display the WiFi Access Point SSID screen.

Tap the appropriate characters from the keyboard into the WiFi Access Point SSID field. The characters are limited to A-Z, a-z, 0-9, ".", "_", and " " [space].

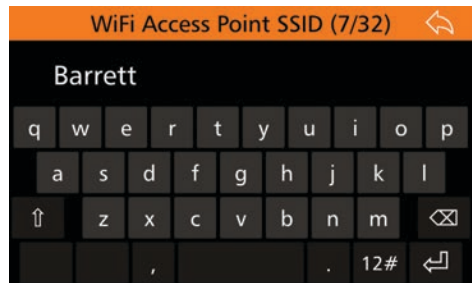

Tap  to save and return to the WiFi Access Point screen.

Password

Tap **Password** from the WiFi Access Point screen to display the WiFi Access Point Password screen.

Tap the appropriate characters from the keyboard into the WiFi Access Point Password field.

NOTE: the password must be between 8 and 63 characters long.

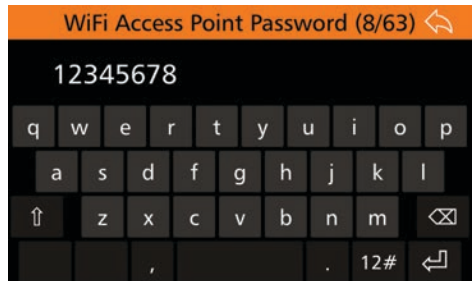

Tap  to save and return to the WiFi Access Point screen.

Access Point Channel

Tap **Access Point Channel** from the WiFi Access Point screen to display the Access Point Channel screen.

Select from channel 0 to 13. Channel 0 is for automatic assignment

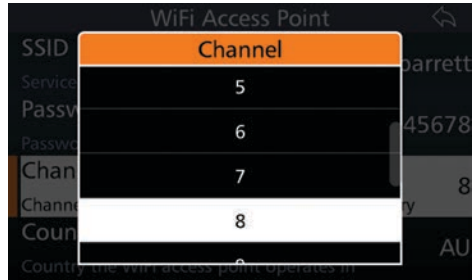

Country

This is to ensure that the channels selected abide by location specific frequency regulations.

Tap **Country** from the WiFi Access Point screen to display the Country screen.

Select the appropriate country.

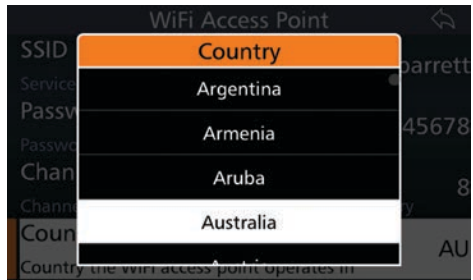

WPS Push Button

Tap **WPS Push Button** (WiFi Protected Setup) from the WiFi Access Point Mode screen to display the WPS Connection screen.

This option initiates the WiFi protected setup.

NOTE: This is an advanced feature not required for the basic functionality of the app or transceiver. To know more, please contact your system administrator.



Connecting

Note: the transceiver must be configured as a WiFi Access Point for this to be successful.

1a. Click the WiFi icon  on the task bar, located on the bottom right hand corner of Windows.

b. Click on the name of the WiFi network, for example, "Barrett".

This is the access point name which was set during the WiFi access point setup on the transceiver.

For iOS devices, go to Settings < WiFi.

For Android devices, either swipe down from the top of the screen and select WiFi or go to Settings < WiFi.

2. Type the password which was set up during the WiFi access point setup.

Note: Ensure to enter the password as 'network security key' rather than 'PIN from the router label'.

Click **Next**.

The computer will then login to the transceiver's access point.

Note: If you cannot login to the transceiver as a WiFi access point, check the password in the access point setup under network settings on the transceiver. (see [page 17](#))

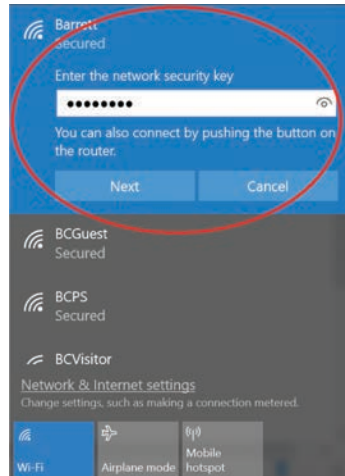
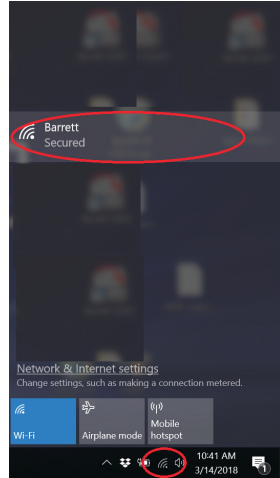

SCENARIO 1 - WiFi Access Point Setup with Windows/iOS/Android Devices

For Windows PCs

The Barrett 4000 Series HF Remote Control app for Windows is provided exclusively by Barrett Communications (P/N BCO40516). This can be purchased separately.

This allows the operator to both program the transceiver via the Barrett 4000 Series HF Programming Software (P/N BCA40001) and use the Barrett 4000 Series HF Remote Control application to access the functionality of the transceiver remotely from their PC.

It is highly recommended to install the Bonjour app prior to installing the Barrett 4000 Series HF Remote Control app.

1. Download the BonjourPSSetup.exe from:

<https://support.apple.com/kb/DL999>

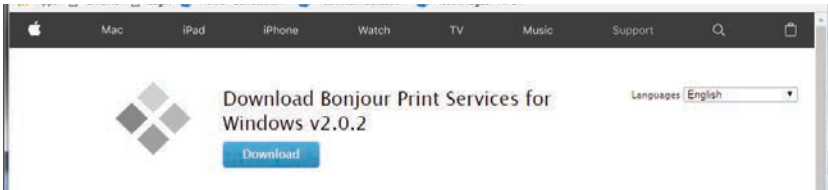

2. Follow the online instructions to install the Bonjour app.

Note: If Bonjour is not installed, no Barrett 4050 HF SDR transceivers will be shown in the connection screen.

Installing the Barrett 4000 Series HF Remote Control (Windows) App

Note: Windows 7 is the minimum system requirement for running this app

1. To install the app, double-click the Barrett 4000 Series HF Remote Control Setup.exe file and follow the prompts. The final installation screen is shown opposite with a reminder to install the Bonjour app, (link provided on the previous page).

Existing installations will be updated

2. Select the **Open Barrett 4000 Series HF Remote Control** checkbox and click **Finish** to display the Connect to SDR screen.
4. Select the device to connect to and tap  or type in a specific IP address if the required transceiver does not appear. Finding your transceiver's IP address is provided in Appendix 5.

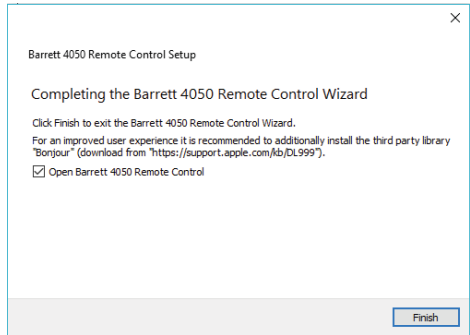

To find out more about this app, turn to the Basic App Features section on [page 25](#).

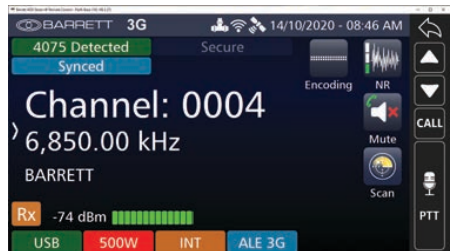

For iOS Devices

The Barrett 4000 Series HF Remote Control app may be downloaded from the App Store (search Barrett 4050). Download and installation should begin automatically.

Please note, that a minimum of iOS 10 is required to run this app.

Turn to [page 24](#) for the Using the Barrett 4000 HF Series Remote Control section of this guide.



For Android Devices

Downloading the Barrett 4000 Series HF Remote Control App

Please note, a minimum of Android version 5.0 (Lollipop) is required to run this app.

There are two ways to download the Barrett 4000 Series HF Remote Control app for Android devices. The first is via the Google Play store. Search "Barrett 4050".

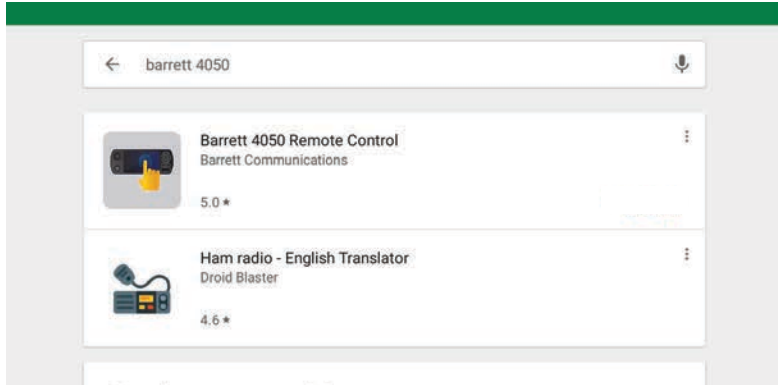

The second is downloading the app directly from the control head of the transceiver.

Ensure that all previous versions of the Barrett 4000 Series HF Remote Control app have been uninstalled before beginning.

1. Insert a USB stick into either the top of the transceiver front panel or via the appropriate adaptor and select "Settings<Export<Export Android Apps".
2. Plug in the USB stick via a USB to micro-USB (On-the-Go) adaptor into the mobile device. The built in file manager should pop up and allow access to the files on the USB stick. If not, go to "My Files< USB Device"
3. Select "Barrett 4000 Series HF Remote Control.apk" and acknowledge the installation of an unknown app (i.e. not installed through Google Play-Store).
4. Open the app and acknowledge the permission requests for microphone use and storage access.

Using the Barrett 4000 Series HF Remote Control App

To open the app, tap the  icon on the wireless device or double click the short cut from the desktop.

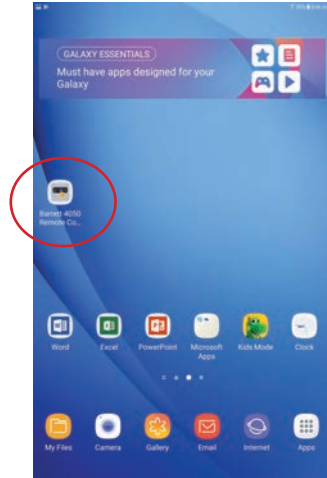

The Connect to SDR screen will appear on start-up.

You may need to type over the transceiver IP address (192.168.3.2 in the example) or simply select the transceiver you wish to connect to and tap  to connect.

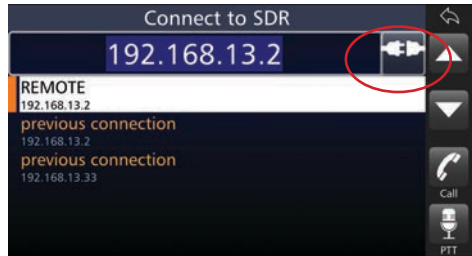

The Connecting screen will disappear and be replaced by the screen on the right.

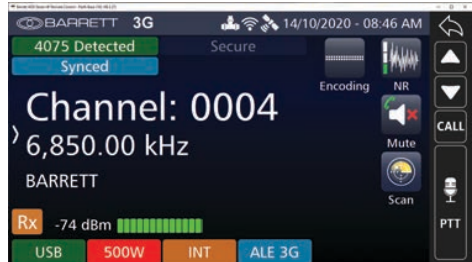

Basic App Features

The display and icons shown on the remote control software are a direct replication of the front panel on the 4050 transceiver, with the additional column of icons replicating the keypad operations of the transceiver.

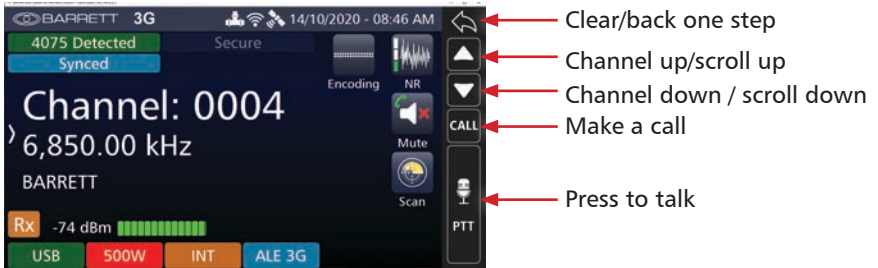

For more information regarding the functionality, please consult the Barrett 4050 HF SDR Transceiver Operating and Installation Manual (P/N BCN40500).

Disconnecting

1. From the swipe screen, select Settings < Network to display the following screen.
2. Tap **Disconnect from SDR** to disconnect from the transceiver.



3. A confirmation screen displays. Tap **Yes**.

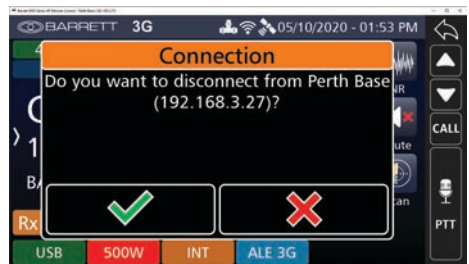

The transceiver has now been successfully disconnected from the network.

SCENARIO 2 - WiFi Client Mode

In this scenario, the transceiver is configured as a WiFi Client. The transceiver logs into an access point/router, (for example, "BCGuest") and The workstation connects to the same WiFi access point/router as the transceiver. This allows the operator to program the transceiver via the Barrett Programming Software, or use the Barrett 4000 Series Remote Control Software to access all the functionality of the transceiver from their workstation.

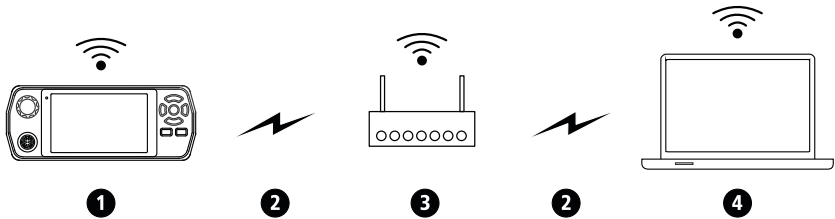

- 1** Barrett Transceiver
 - WiFi Adapter (P/N BCO40508)
 - Setup as WiFi Client
 - DHCP
- 2** WiFi Link
- 3** WiFi Access Point/Router (not supplied)
 - DHCP Server
- 4** Workstation with WiFi link to Access Point (not supplied)
 - DHCP
 - Barrett 4000 Series Remote Control Software (P/N BCO40516)
 - Install Bonjour for discovery

Setting up the transceiver as WiFi Client

Prior to beginning the installation, ensure the **TP-Link** WiFi adapter is inserted in the USB socket located on the top of the front panel of the transceiver or in the top of the Handset USB Interface on the Control Handset.

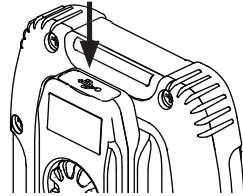

1. From the swipe screen, select **Settings < Network**.

The current status of the WiFi Operation Mode is displayed on the right of the screen.



2a. Tap **WiFi Operation Mode** from the Network screen to display the WiFi Operation Mode screen.

- b. Select **WiFi Client**.

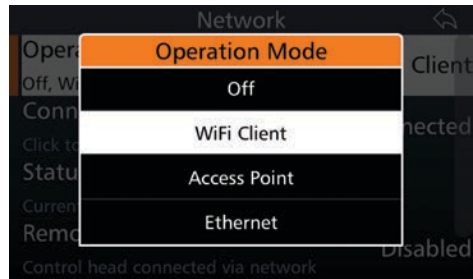

3. Tap **Connection** from the Network screen to display the Network Connection screen.

Select a WiFi network to connect to from the list.

Tap **Rescan WiFi**, if necessary, to display more WiFi networks.

5. Tap **Connect to Network**.

Enter the appropriate password and tap  to submit.

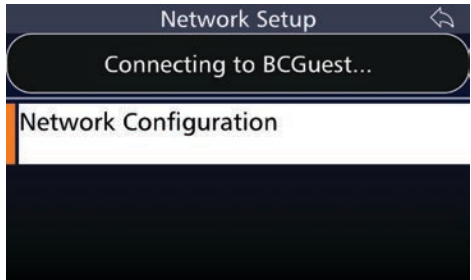
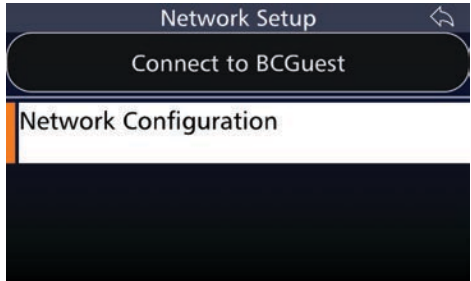
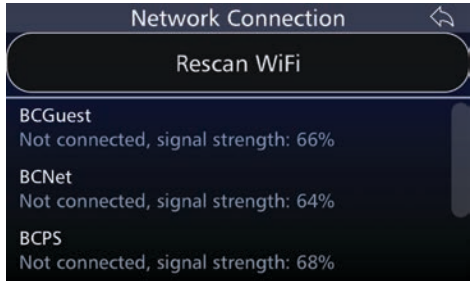

This screen indicates that the transceiver is connected to the network.

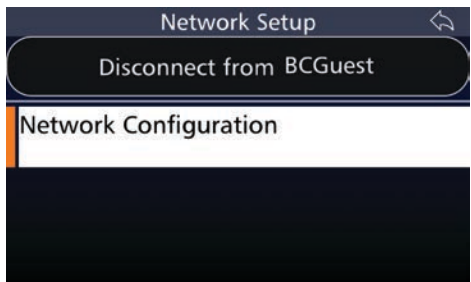

Setting up the PC

6a. Click the WiFi icon  on the task bar.

b. Click the name of the WiFi Access Point. For example, "BCGuest". This should be the same network as the transceiver.

Enter the password and click Next.

Open the Remote Control App on the PC and connect to the transceiver (see [page 24](#))

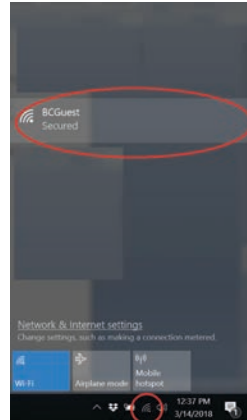

ETHERNET SET-UP SCENARIOS 3

This chapter contains the following sections:

- Scenario 3 - Ethernet Adaptor/Switch/PC
- Scenario 4 - Ethernet Adaptor/Switch/DHCP Server/ PC
- Scenario 5 - Ethernet Adaptor/Router (VPN)/Internet/Router/PC (Recommended)

SCENARIO 3 - Ethernet/Switch/PC

This basic setup is comprised of a transceiver, Ethernet Adaptor, switch and a computer. An Ethernet cable is connected to the adaptor and the switch, and another Ethernet cable between the switch and the computer as per the diagram below.

For the connection between the Windows PC and the 4000 Series HF SDR Transceiver to operate, both should have matching static IP addresses. The PC should already be installed with the Barrett 4000 Series HF Remote Control app (P/N BCO40516), Barrett 4000 Series HF Programming Software (P/N USB40001) and Bonjour. For instructions on installing this software, please refer to [page 20](#).

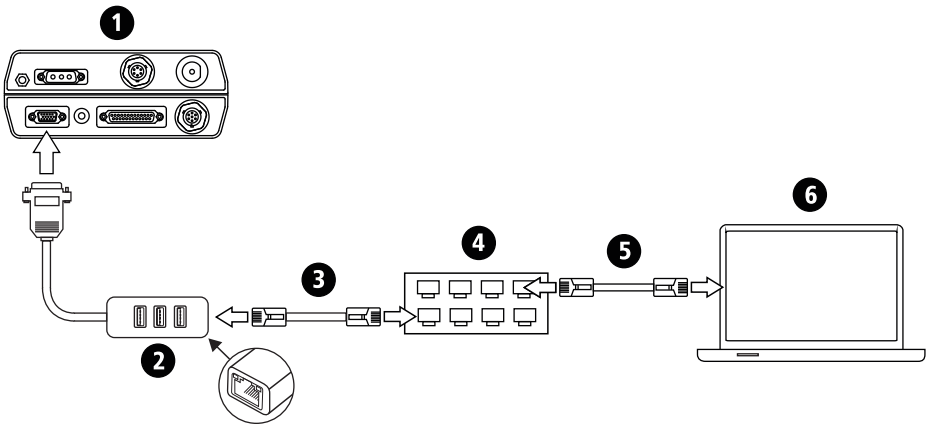

- | | |
|----------|--|
| 1 | Barrett 4050 HF SDR Transceiver (P/N BC405000) |
| 2 | 4050 to Ethernet Adaptor with USB ports (P/N BCA40504) |
| 3 | Ethernet cable (not supplied) |
| 4 | Switch (not supplied) |
| 5 | Ethernet cable (not supplied) |
| 6 | PC with Barrett 4000 Series Remote Control Software <ul style="list-style-type: none"> • Static IP e.g. 192.168.1.20 • Subnet Mask e.g. 255.255.255.0 • Bonjour installed |

with Control Handset

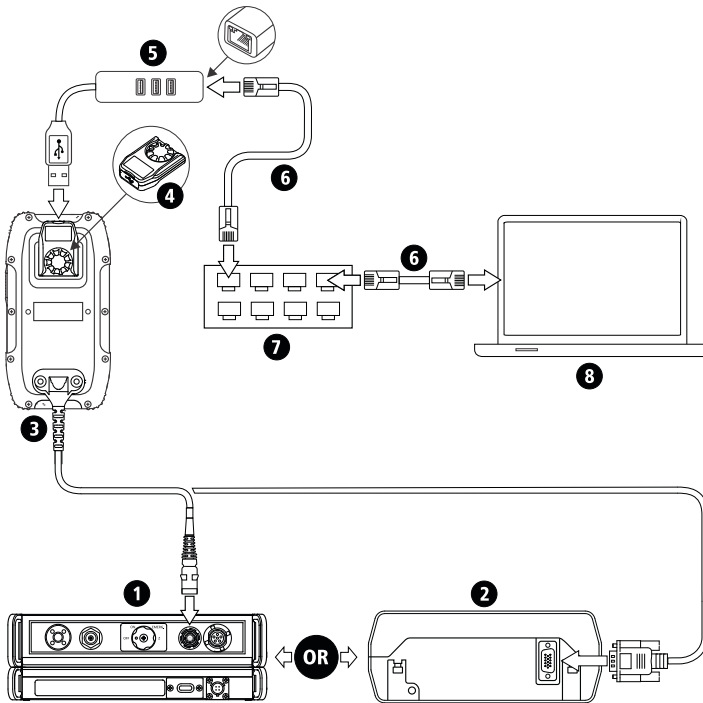

- 1 Barrett PRC-4090 HF SDR Transceiver (P/N 4090-00-10)
- 2 Barrett 4050 HF SDR Transceiver (P/N BC405000)
- 3 Control Handset (P/N 4090-01-09)
- 4 PRC-4090 Handset USB Interface (4090-01-27)
- 5 4050 to Ethernet Adaptor with USB ports (P/N BCA40504)
- 6 Ethernet cable (not supplied)
- 7 Switch (not supplied)
- 8 Computer with Barrett 4000 Series Remote Control Software
 - Static IP e.g. 192.168.1.20
 - Subnet Mask e.g. 255.255.255.0
 - Bonjour installed

Ethernet Port

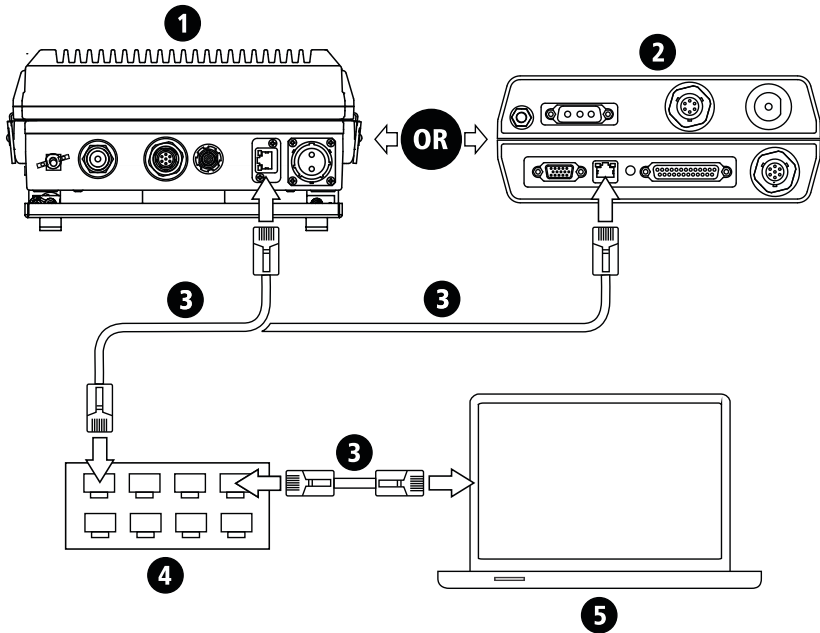

- 1 Barrett PRC-4090 HF SDR Transceiver and SDS (P/N 4091-00-10)
- 2 Barrett 4050 HF SDR Transceiver (P/N BC405000)
- 3 Ethernet cable (not supplied)
- 4 Switch (not supplied)
- 5 PC with Barrett 4000 Series Remote Control Software (PC not supplied; Barrett 4000 Remote Control Software P/N BCO40516)
 - Static IP e.g. 192.168.1.20
 - Subnet Mask e.g. 255.255.255.0
 - Bonjour installed

Setting up a Static IP Address on Windows 10 Professional

The following steps indicate how to set up a Windows PC with a static IP address. A Default Gateway and DNS information are not required and can be left blank for this scenario.

1. To set up the computer as a DHCP client, **right-click the start button** and choose **Network Connections**.

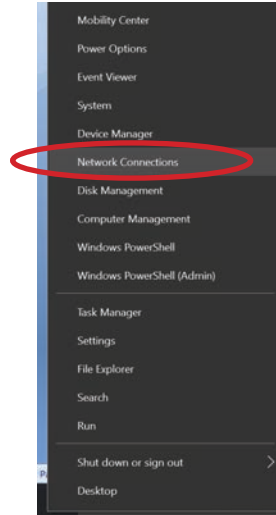

2. Choose “**change adapter options**”

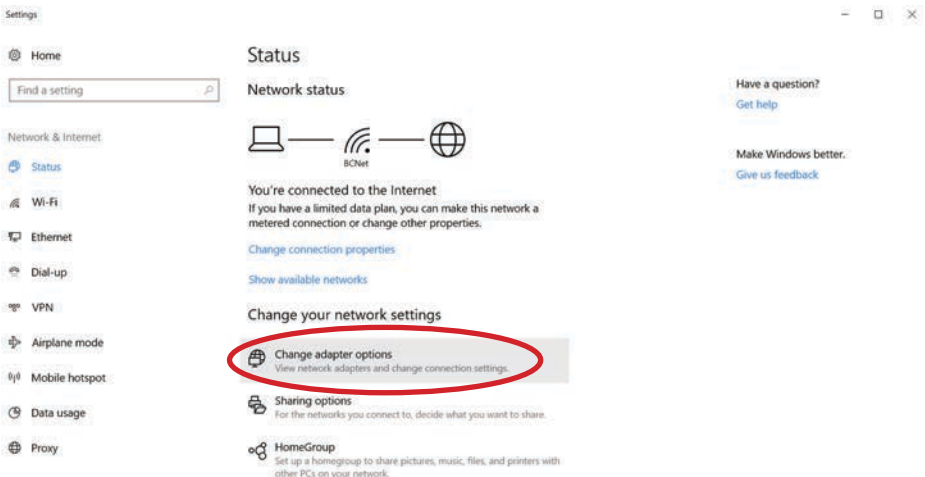

3. Right-click Connection and choose Properties.

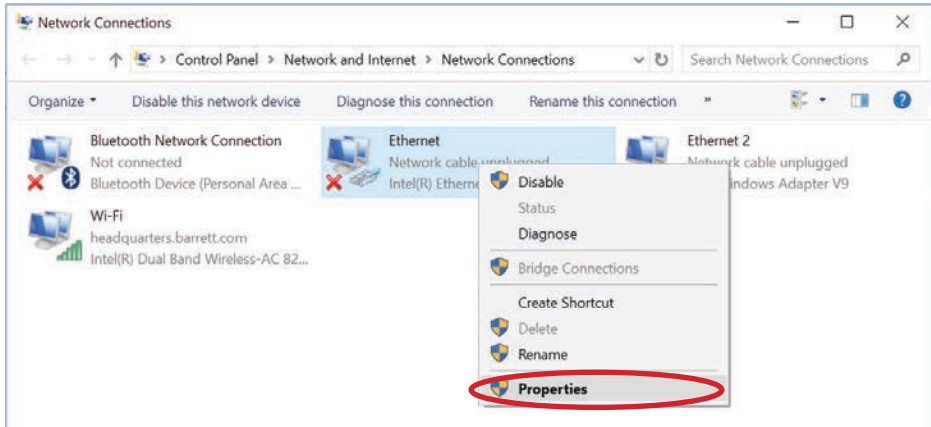

4. Click Internet protocol version 4, then click Properties.

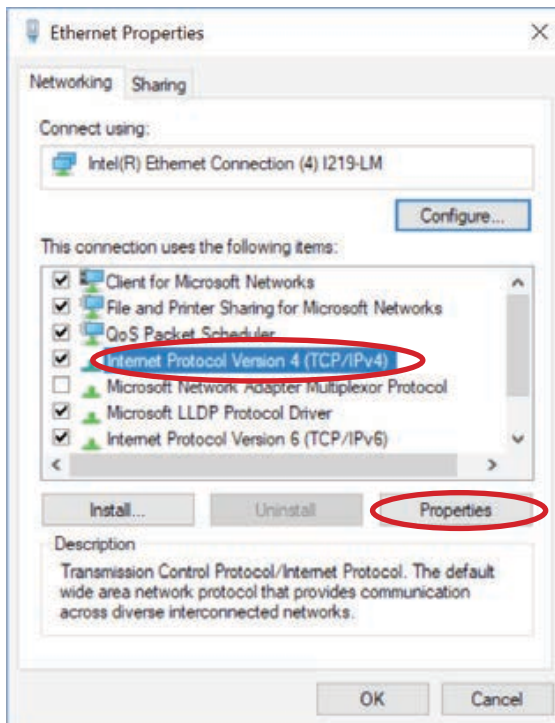

5. Click **“Use the following IP address”**, set it to, for example, 192.168.1.20 and enter the subnet mask as, for example, 255.255.255.0.

The default gateway and DNS are left blank, then click OK.

You can obtain an IP address from your network administrator.

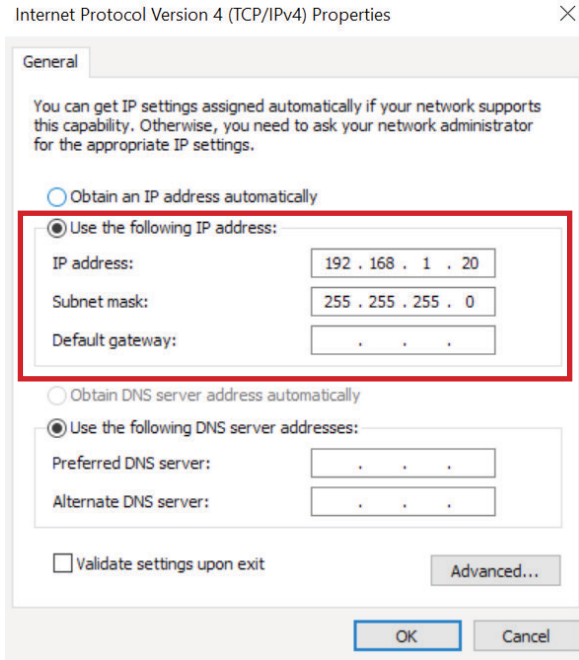

Selecting Obtain an IP address automatically will reverse this procedure.

Setting up a Static IP Address on a 4000 Series Transceiver

The following steps show how to set up the control head with a static IP. A default gateway and DNS information are not required and can be left to 0.0.0.0.

Ensure the USB-Ethernet adaptor is connected to an active LAN before beginning this procedure.

1. From the 4050/4090 transceiver's Settings screen, tap **Network**
 to display the Network screen.
2. Change the Operation Mode to "Ethernet"

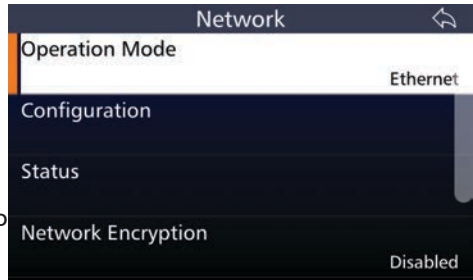

Configuration

Tap **Configuration** from the Network screen to display the Network Configuration screen.

These configuration settings can be set with either IPv4 or IPv6 formatting

A list of items that may be configured displays. To reveal more items, either swipe down on the touch screen or press .

The current status of each of the items is displayed on the right of screen.

Each item on the list is described in more detail below.

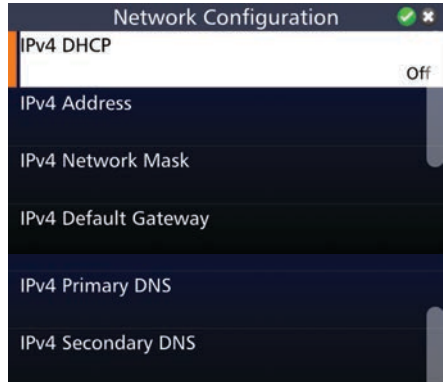

DHCP

Switch to "Off" when setting a static IP address.

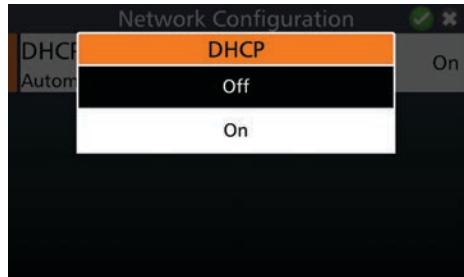

IP Address

Tap **IP Address** from the Network Settings screen to display the IP Address screen.

Use the keyboard to type or edit the IP Address, then tap  to save.

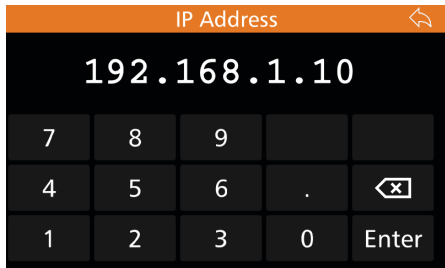

Network Mask

Tap **Network Mask** from the Network Settings screen to display the Network Mask screen.

Use the keyboard to type or edit the Network Mask, then tap  to save.

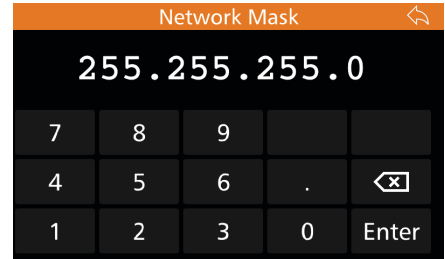

Default Gateway

Tap **Default Gateway** from the Network Settings screen to display the Default Gateway screen.

Use the keyboard to type or edit the Default Gateway, then tap  to save.

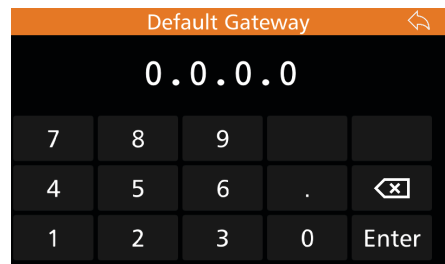

Primary DNS

Tap **Primary DNS** from the Network Settings screen to display the Primary DNS screen.

Use the keyboard to type or edit the Primary DNS, then tap  to save.

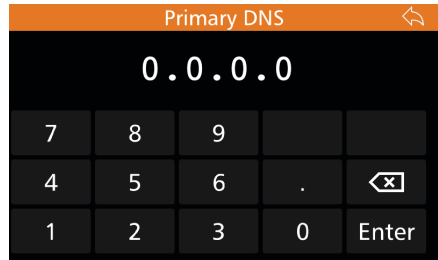

Secondary DNS

Tap **Secondary DNS** from the Network Settings screen to display the Secondary DNS screen.

Use the keyboard to type or edit the Secondary DNS, then tap  to save.

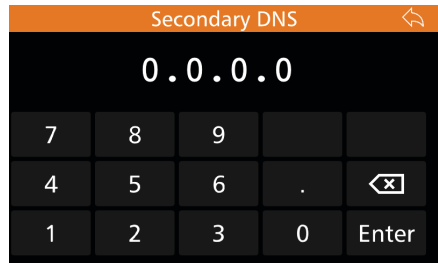

The current IP address will appear under "Status" in the Network menu.

Note: the static IP configuration will not save if the Ethernet cable is not properly connected.

SCENARIO 4 - Ethernet/Switch/DHCP Server/PC

This set up comprises of a transceiver, Ethernet Adapter, switch, DHCP server and a computer. The DHCP server could also be installed on the switch, on the computer as an application, or on a server in a larger network as shown in the diagram below. Please consult your network administrator as to the location of your DHCP server.

This may be useful if the transceiver is set up in a LAN configuration. An operator/administrator with a computer set up in a different room to the transceiver but on the same network, can control and program the transceiver from their location via the Barrett 4000 Series Remote Control app (P/N BCO40516). For instructions on the loading of this software, refer to [page 21](#).

For more information on DHCP servers, please refer to Appendix 1 - Setting up DHCP on Windows 10 Professional on [page 53](#). These are examples only and may differ slightly for your situation. If more information is required ask your network administrator about your network setup.

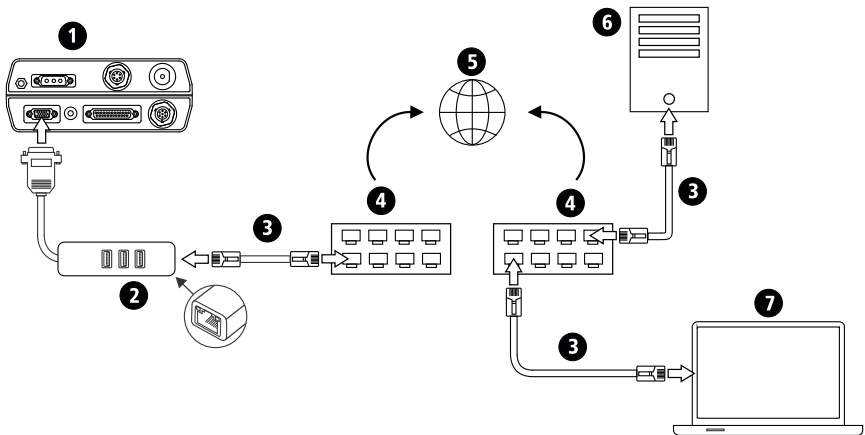

- 1 Barrett 4050 HF SDR Transceiver (P/N BC405000)
- 2 4050 to Ethernet Adaptor with USB ports (P/N BCA40504)
- 3 Ethernet cable (not supplied)
- 4 Switch (not supplied)
- 5 Internet connection
- 6 DHCP Server (not supplied)
- 7 PC with Barrett 4000 Series Remote Control Software (PC not supplied; Barrett 4000 Series Remote Control Software P/N BCO40516)
 - DHCP
 - Bonjour installed

4050/4090 Control Handset

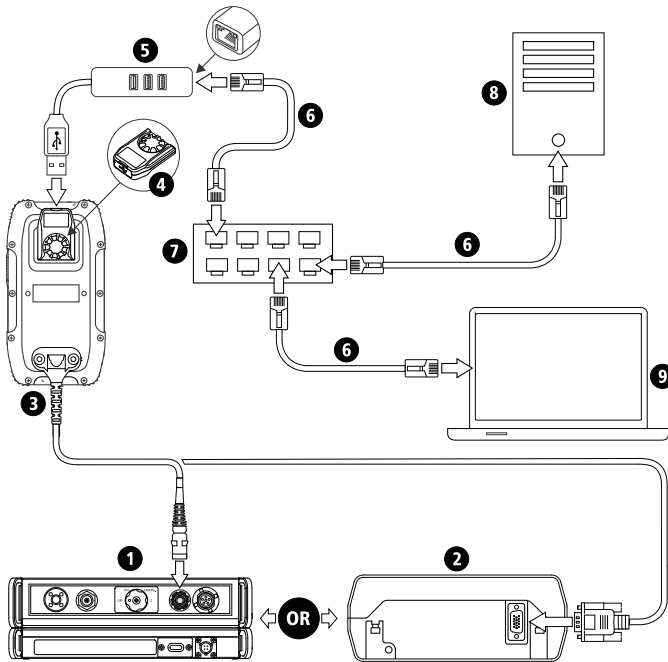

- 1** Barrett PRC-4090 HF SDR Transceiver (P/N 4090-00-10)
- 2** Barrett 4050 HF SDR Transceiver (P/N BC405000)
- 3** Control Handset (P/N 4090-01-09)
- 4** PRC-4090 Handset USB Interface (4090-01-27)
- 5** 4050 to Ethernet Adaptor with USB ports (P/N BCA40504)
- 6** Ethernet cable (not supplied)
- 7** Switch (not supplied)
- 8** DHCP Server (not supplied)
- 9** PC with Barrett 4050 Remote Control app
(computer not supplied; Barrett 4050 Remote Control app
P/N BCO40516)
 - DHCP
 - Bonjour installed

Ethernet port

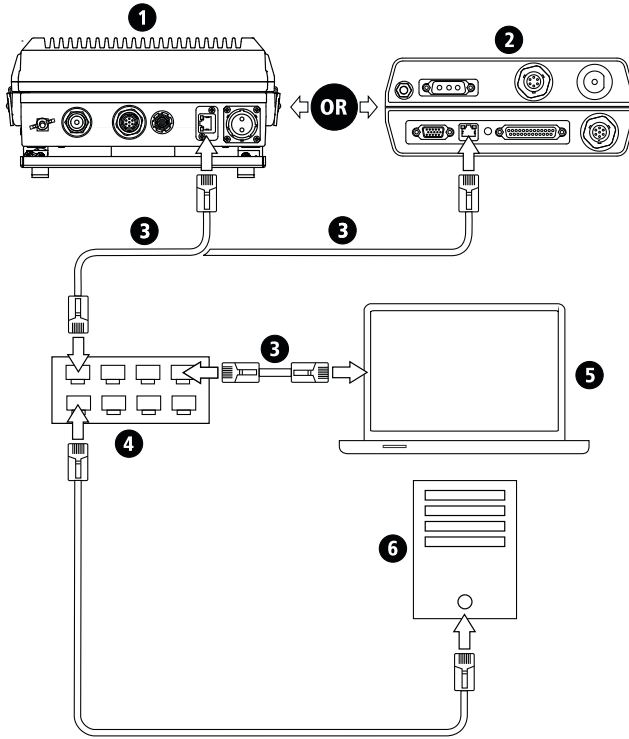

- 1 Barrett PRC-4090 HF SDR Transceiver and SDS (P/N 4091-00-10)
- 2 Barrett 4050 HF SDR Transceiver (P/N BC405000)
- 3 Ethernet cable (not supplied)
- 4 Switch (not supplied)
- 5 Computer with Barrett 4050 Remote Control app (computer not supplied; Barrett 4050 Remote Control app P/N BCO40516)
 - DHCP
 - Bonjour installed
- 6 DHCP Server (not supplied)

Enabling a DHCP Generated IP Address on a 4000 Series HF Transceiver

Ensure that the Network's Operation Mode is set to Ethernet, before beginning this procedure.

From the transceiver's settings menu, tap the **Network icon**, then tap **Configuration**. Tap **DHCP** and select **on**.

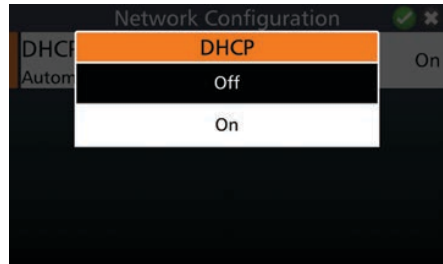

Network Status

Tap **Network Status** to display the Network Status screen.

A list of items will display. To reveal more items, either swipe down on the touch screen or press .

The current setting of each of the items is displayed to the right.

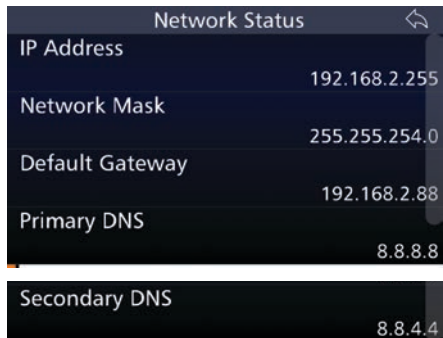

If this has been completed correctly, the transceiver and PC should now be able to connect via the Barrett 4000 Series HF Remote Control app and/or Barrett 4000 Series HF Programming Software.

SCENARIO 5 - Ethernet Adapter/Router (VPN)/ Internet/Router/PC

This scenario shows a configuration using an Ethernet Adapter, router/gateway, Internet, router/gateway, server and Windows PC. One benefit of this scenario is the added security that a VPN provides the operator. Another is that in this configuration is the operator can be outside the LAN, and have access to the transceiver via a secure network. This setup would benefit a communications manager who could securely maintain the transceiver network remotely via the Barrett 4000 Series HF Remote Control app (P/N BCO40516). For instructions on the loading of this software, refer to [page 21](#).

Please refer to Appendix 4 - Setting up a VPN on [page 60](#). These are examples only and may differ in your situation. If more information is required, ask your network administrator about your network setup.

For help assigning ports through a firewall, please refer to Appendix 3 - Allowing Ports with a Firewall on Windows 10 Professional on [page 58](#). These are examples only and may differ in your situation. If more information is required, ask your network administrator about your network setup.

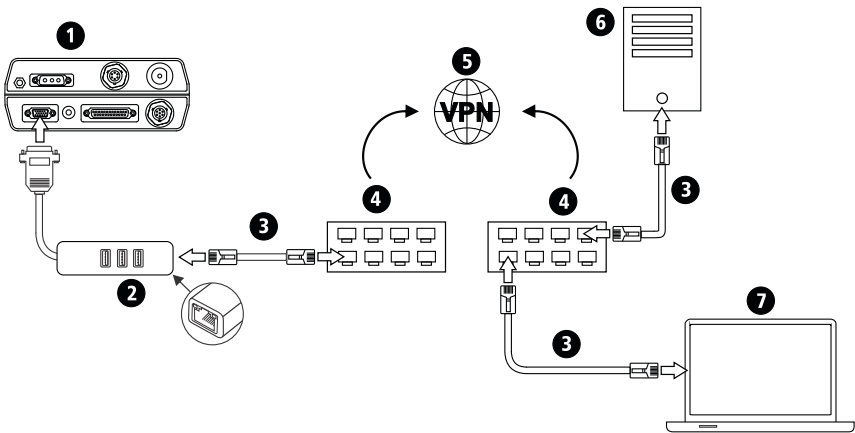

- 1 Barrett 4050 HF SDR Transceiver (P/N BC405000)
- 2 4050 to Ethernet Adaptor with USB Ports (P/N BCA40504)
- 3 Ethernet cable (not supplied)
- 4 Router / Gateway (not supplied)
 - DHCP
 - VPN Server
- 5 VPN
- 6 DHCP Server (not supplied)
- 7 PC with Barrett 4000 Series Remote Control Software. (PC not supplied; Barrett 4000 Series Remote Control Software P/N BCO40516)
 - DHCP
 - VPN Client Setup
 - Port forwarding for incoming data in windows firewall UDP: 55570-55586

4050/4090 Control Handset

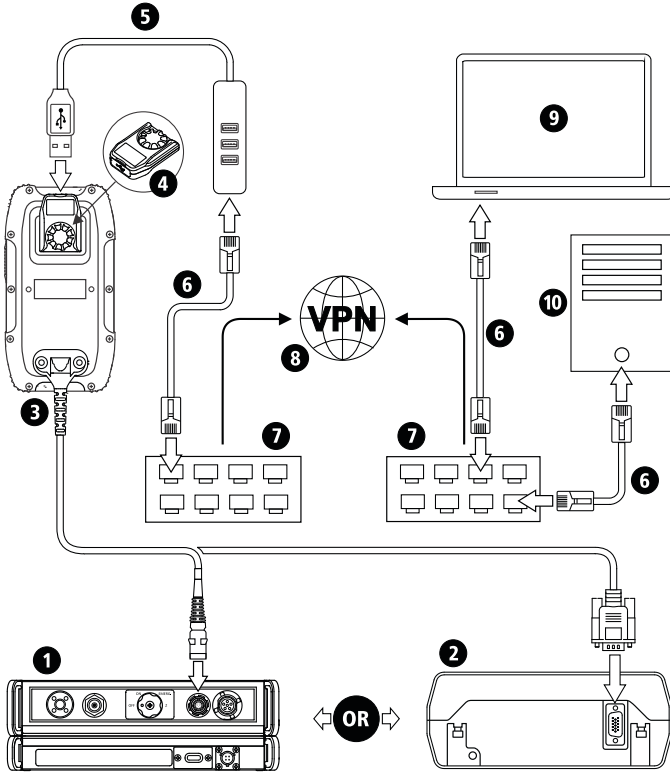

- ① Barrett PRC-4090 HF SDR Transceiver (P/N 4090-00-10)
- ② Barrett 4050 HF SDR Transceiver (P/N BC405000)
- ③ Control Handset (P/N 4090-01-09)
- ④ PRC-4090 Handset USB Interface (4090-01-27)
- ⑤ 4050 to Ethernet Adaptor with USB ports (P/N BCA40504)
- ⑥ Ethernet cable (not supplied)
- ⑦ Switch (not supplied)
- ⑧ VPN

- 9 Computer with Barrett 4050 Remote Control app
(computer not supplied; Barrett 4050 Remote Control app
P/N BCO40516)
 - DHCP
 - Bonjour installed
- 10 DHCP Server (not supplied)

Ethernet port

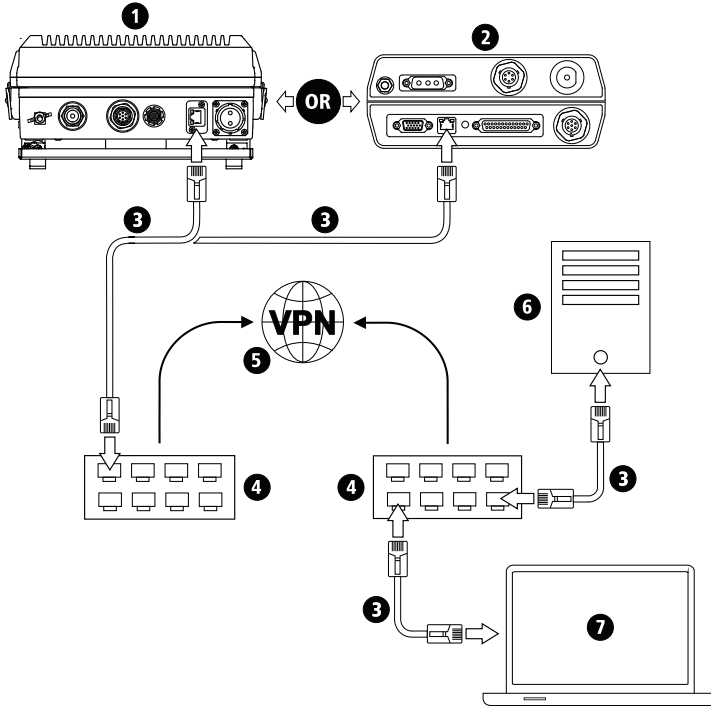

- 1 Barrett PRC-4090 HF SDR Transceiver and SDS (P/N 4091-00-10)
- 2 Barrett 4050 HF SDR Transceiver (P/N BC405000)
- 3 Ethernet cable (not supplied)
- 4 Router / Gateway (not supplied)
- 5 VPN
- 6 DHCP Server (not supplied)
- 7 PC with Barrett 4050 Remote Control application. (PC not supplied; Barrett 4050 Remote Control application P/N BCO40516)
 - DHCP
 - VPN Client Setup
 - Port forwarding for incoming data in windows firewall UDP: 55570-55586

APPENDICES 4

This section includes the following guides:

- APPENDIX 1 - Recommended Network Specifications
- APPENDIX 2 - Setting up DHCP on Windows 10 Professional
- APPENDIX 3 - Setting up Port Forwarding in your Router
- APPENDIX 4 - Allowing Ports with a Firewall on Windows 10 Professional
- APPENDIX 5 - Setting up a VPN
- APPENDIX 6 - Finding your Transceiver's IP Address
- APPENDIX 7 - Troubleshooting

APPENDIX 1 - Recommended Network Specifications

Minimum requirements:

- Bandwidth: 40kbytes/s both ways (audio uses 20kbytes/s)
- Delay: max. 150ms (one way delay, round trip must be less than 300ms, larger delays will also affect data communication between remote control software and 4050/4090; based on best practices VoIP)
- Jitter: 30ms (based on best practices VoIP)
- Loss: max 1% (based on best practices VoIP)
- Configured firewall on laptop/workstation and routers/modems according to Appendix 4, [page 58](#).
- Controlhead acts as a WiFi client and connects to a WiFi access point
- DHCP server
- IPv4
- If Internet traversal is required, a VPN connection is necessary

Recommended:

- Networking preference:
 1. Ethernet via control head (available since v1.6); Control head as WiFi access point
 2. Control head as WiFi client
- Dedicated network between the 4050/4090 and remote control and configuration software
- Same subnet (e.g. 192.168.1.x/24), i.e. no routing necessary
- Ethernet: 100Mbit/s or greater
- WiFi: prefer 11g mode (access point setting)
- Static IP address setup (available since transceiver firmware v1.6)
- No routers
- No firewalls (within the network and on the workstation running the 4000 Series remote control and/or configuration software)
- No VPN

APPENDIX 2 - Setting up DHCP on Windows 10 Professional

Dynamic Host Configuration Protocol (DHCP) is a client/server protocol that automatically provides an Internet Protocol (IP) host with its IP address and other related configuration information such as the subnet mask and default gateway.

The DHCP is controlled by a DHCP server that dynamically distributes network configuration parameters, such as IP addresses, for interfaces and services.

1. To set up the computer as a DHCP client, right-click the start button and choose Network Connections.

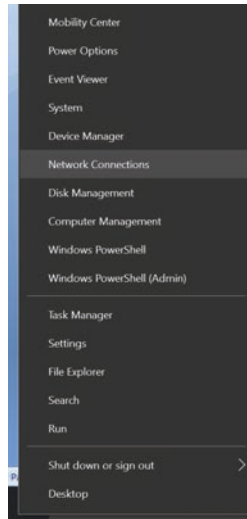

2. Then choose “change adapter options”

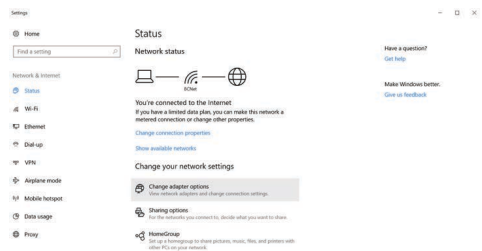

3. Right-click Connection and choose Properties.

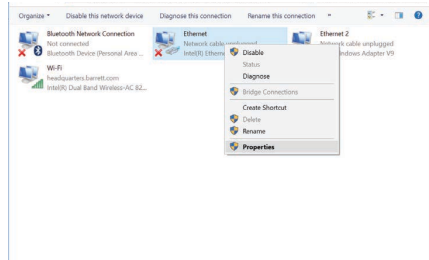

4. Click Internet protocol version 4, then click Properties.

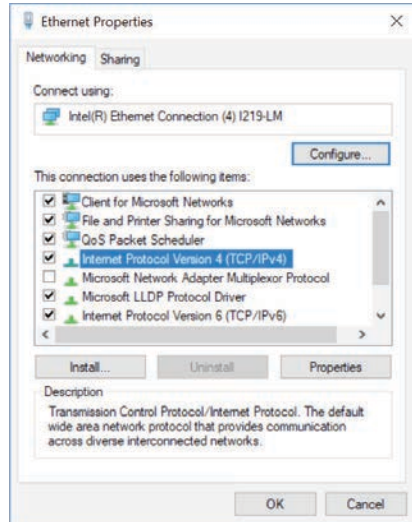

5. Click “Obtain an IP address automatically”, then click OK.

The IP address is being obtained from the DHCP Server.

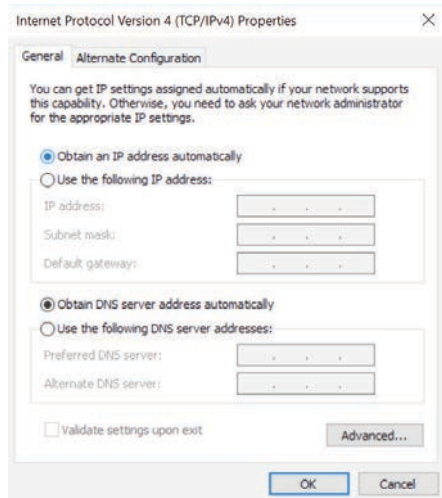

APPENDIX 3 - Setting up Port Forwarding in your Router

This guide briefly explains port forwarding. Every router is different so please refer to the manufacturer's instructions.

In computer networking, port forwarding or port mapping is an application of network address translation (NAT) that redirects a communication request from one address and port number combination to another while the packets are traversing a network gateway, such as a router or firewall.

1. Log in to Router as per manufacturer's instructions.
2. Under NAT or the port forwarding menu, enter the ports you wish to forward to the networked Transceiver.

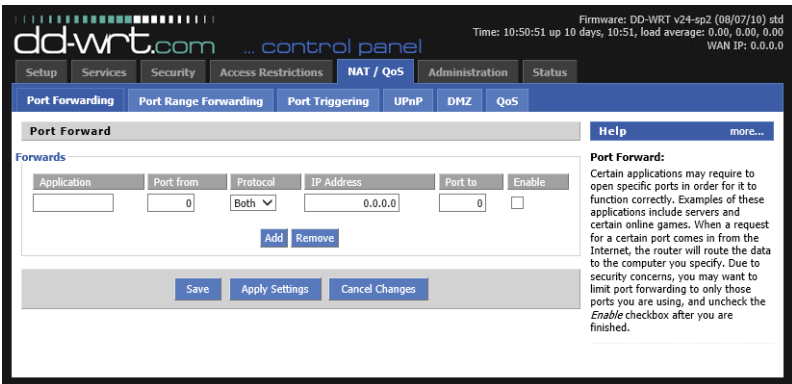

3. From the port forwarding menu under application, enter a description for the rule, then enter the port number you are forwarding from, the protocol (which is TCP for this example), the IP address your are forwarding to (the Transceiver), and the Port you are forwarding to. You have the choice to enable/disable this port forwarding rule by selecting the checkbox.

The following screen shot shows the port forwarding rules that are required.

The screenshot shows the dd-wrt control panel interface. At the top, it displays the dd-wrt logo and the text "... control panel". The system information at the top right includes: Firmware: DD-WRT v24-sp2 (08/07/10) std, Time: 10:56:44 up 10 days, 10:56, load average: 0.06, 0.05, 0.00, and WAN IP: 0.0.0.0. The navigation menu includes Setup, Services, Security, Access Restrictions, NAT / QoS (selected), Administration, and Status. The sub-menu for NAT / QoS includes Port Forwarding (selected), Port Range Forwarding, Port Triggering, UPnP, DMZ, and QoS. The main content area is titled "Port Forward" and contains a "Forwards" section with a table of port forwarding rules. To the right of the table is a "Help" section with a "more..." link. At the bottom of the table are "Add" and "Remove" buttons. Below the table are "Save", "Apply Settings", and "Cancel Changes" buttons.

Application	Port from	Protocol	IP Address	Port to	Enable
4050a	55556	TCP	192.168.1.10	55556	<input checked="" type="checkbox"/>
4050b	55558	TCP	192.168.1.10	55558	<input checked="" type="checkbox"/>
4050c	55565	UDP	192.168.1.10	55565	<input checked="" type="checkbox"/>
4050e	58001	TCP	192.168.1.10	58001	<input checked="" type="checkbox"/>

[Add](#) [Remove](#)

[Save](#) [Apply Settings](#) [Cancel Changes](#)

Port Forward:
Certain applications may require to open specific ports in order for it to function correctly. Examples of these applications include servers and certain online games. When a request for a certain port comes in from the Internet, the router will route the data to the computer you specify. Due to security concerns, you may want to limit port forwarding to only those ports you are using, and uncheck the *Enable* checkbox after you are finished.

APPENDIX 4 - Allowing Ports with a Firewall on Windows 10 Professional

In some circumstances you will have to allow ports to be opened through a Windows Firewall. The following steps show how to enable this.

1. The following message appears once you have installed the Barrett 4000 Series Remote Control Software. Click **Allow access** to open the ports necessary for the control head app to operate.

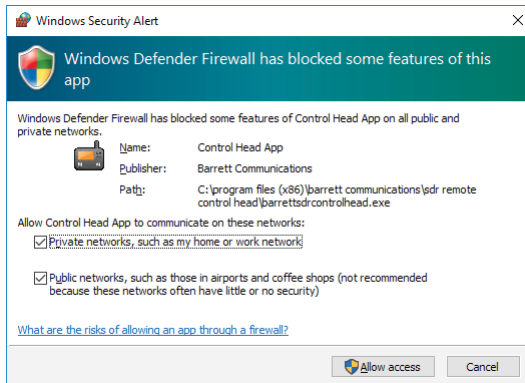

2. Under advanced settings of the Windows firewall, check or change the port settings. Type in the Windows search field "Firewall", to access the advanced menu.

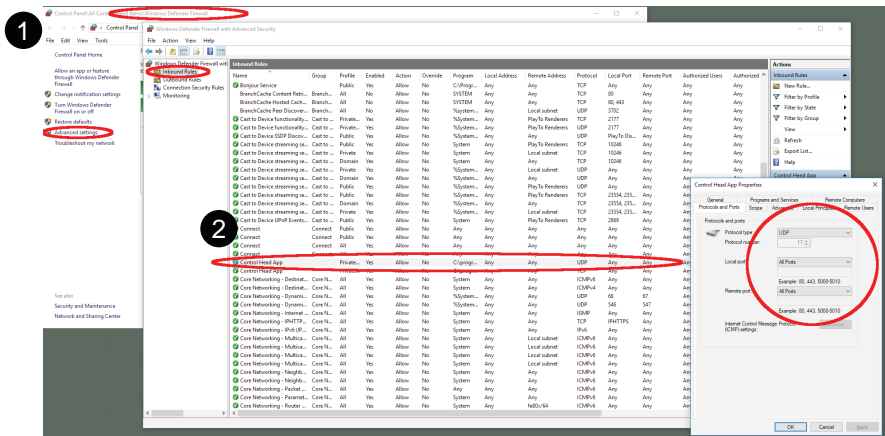

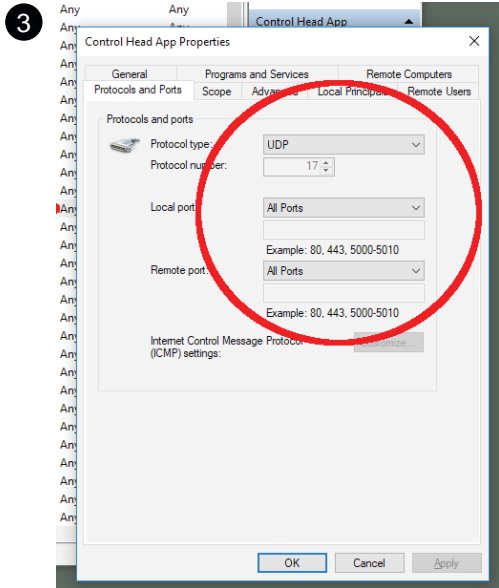
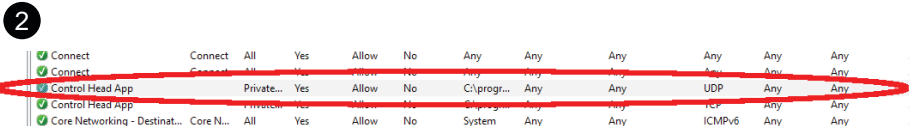
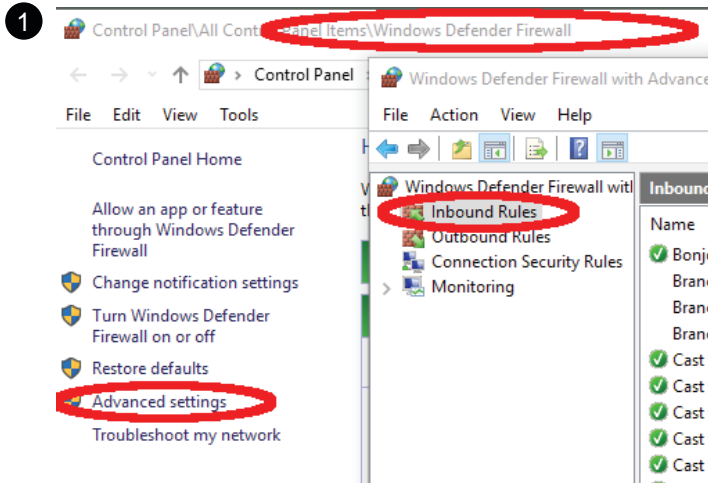

APPENDIX 5 - Setting up a VPN

A virtual private network extends a private network across a public network, and enables users to send and receive data across shared or public networks as if their computing devices were directly connected to the private network.

Applications operating across the VPN may therefore benefit from the functionality, security, and management of the private network. The following example shows how to set up an openVPN server. There are various software available online.

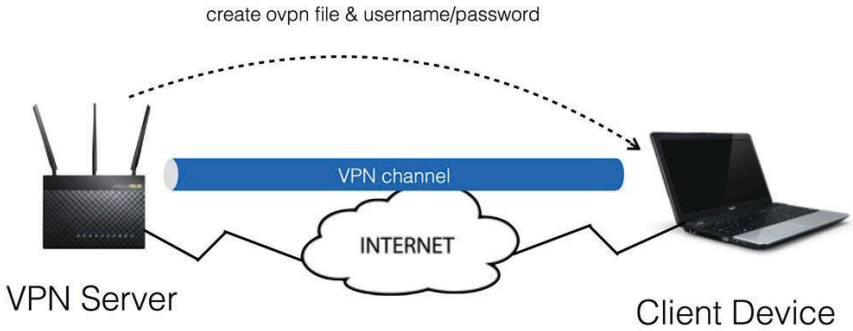

General Settings

Follow the steps below to create your own OpenVPN server :

1. Select server mode as [OpenVPN]

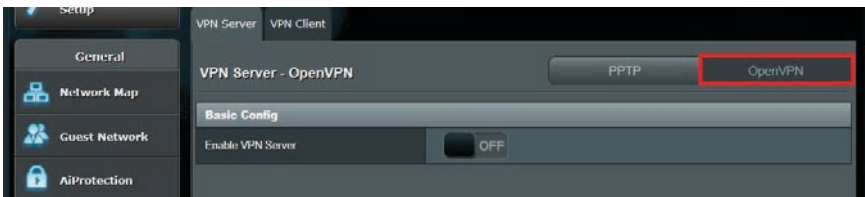

2. Enable the VPN server.

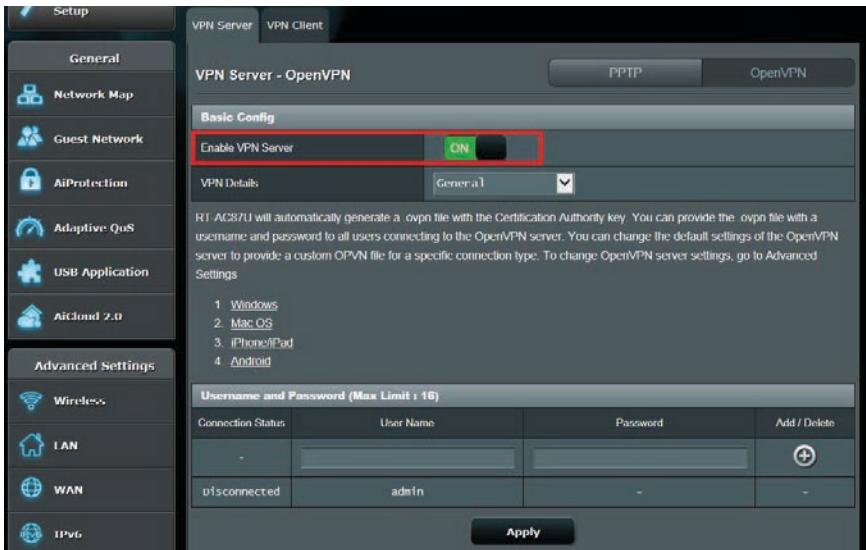

3. Enter your username and password, and click “+” to create a new account for your OpenVPN server

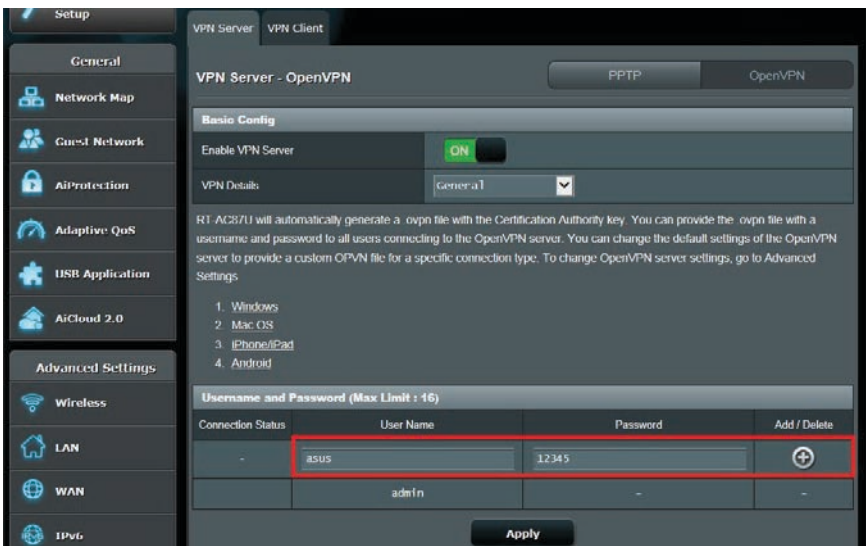

4. Click Apply to save OpenVPN settings.

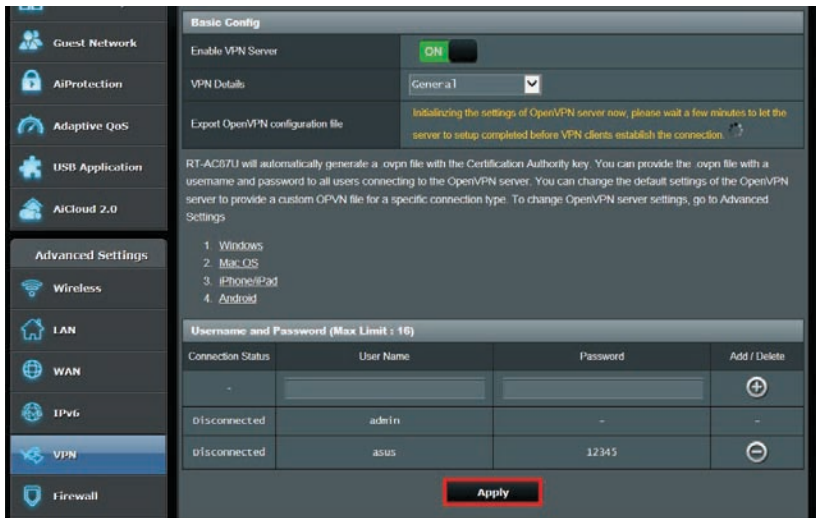

5. It will take a few minutes to initialise the settings of the OpenVPN server and generate an OpenVPN configuration file. Then, click Export to save the ovpn configuration file named "client.ovpn".

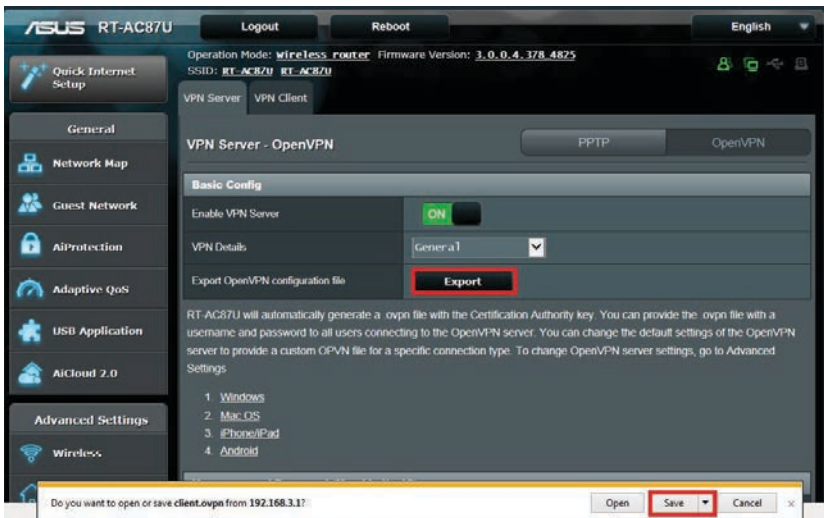

To complete the OpenVPN server side setting, turn to client side to build your OpenVPN client connection. For detail settings regarding OpenVPN client, please refer to the following FAQs displayed on the setting page of the router.

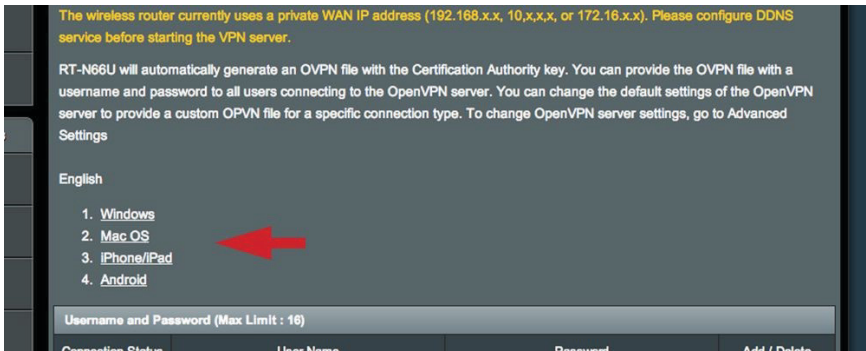

Advanced Settings

If necessary, go to the Advanced Settings page to perform further configuration.

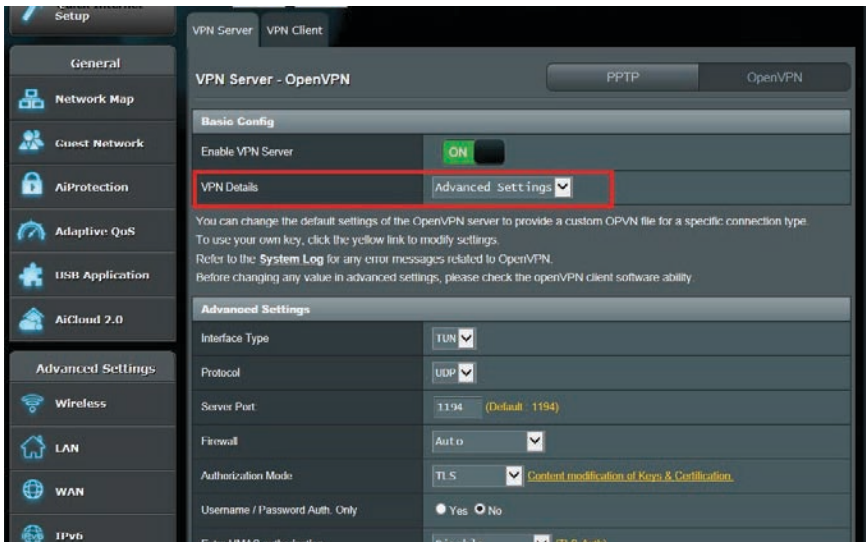

APPENDIX 6 - Finding your Transceiver's IP Address

Settings < Network. The Status item shows the current IP address if successfully connected.

This is also displayed in the Status Info menu, accessed from the swipe menu.

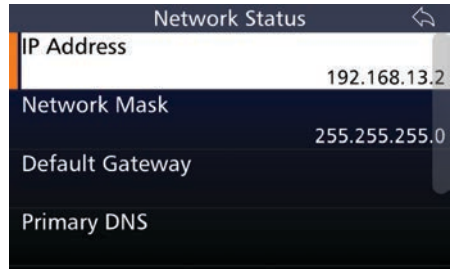

APPENDIX 7 - Troubleshooting

Trouble connecting between transceiver and device and/or intermittent audio

Possible cause 1: Poor connection speed

Action: Ping the transceiver's IP address from the device. To do this, search your Windows PC for "cmd". Type "ping" space IP address of the transceiver.

On iOS or Android devices, many free apps are available with this capability. Search the App Store or Google Play Store with "Ping IP".

```

Command Prompt
Microsoft Windows [Version 10.0.16299.611]
(c) 2017 Microsoft Corporation. All rights reserved.

C:\>ping 192.168.13.2

Pinging 192.168.13.2 with 32 bytes of data:
Reply from 192.168.13.2: bytes=32 time=8ms TTL=64
Reply from 192.168.13.2: bytes=32 time=1ms TTL=64
Reply from 192.168.13.2: bytes=32 time=1ms TTL=64
Reply from 192.168.13.2: bytes=32 time=1ms TTL=64

Ping statistics for 192.168.13.2:
    Packets: Sent = 4, Received = 4, Lost = 0 (0% loss),
    Approximate round trip times in milli-seconds:
        Minimum = 1ms, Maximum = 8ms, Average = 2ms

C:\>
  
```

If ping times exceed 300ms, Barrett cannot guarantee normal operation with the app. To improve network performance, speak to your network administrator.

Possible cause 2: Default Gateway has not been entered

Action: Check that this has been entered. This is necessary for connecting across multiple networks, i.e. the Internet. Confirm your default gateway with your network administrator.

Windows 10 PC will not accept WiFi Access Point password when connecting to transceiver

Possible cause: On Windows 10, the access point password set up on the transceiver is actually a network key, not a PIN.

Action: Click the link that reads "connect using security key instead". Enter the password from the transceiver.

Warranty Statement

Barrett Communications (hereafter referred to as 'Seller') provides a three (3) year warranty on all Barrett products from the date of shipment from the Seller. A one (1) year warranty from the date of shipment from the Seller is provided for all batteries.

Each warranty guarantees acceptable performance of the product under normal recommended conditions for the duration of the warranty period. In cases of accident, abuse, incorrect installation or maintenance by a non-Seller representative, subjection to abnormal environmental conditions, negligence or use other than those in accordance with instructions issued by the Seller, the warranty shall be voided. In addition, this warranty shall not cover low performance – specifically the distance or quality of transmission and reception - due to unfavourable environmental or locational conditions. Nor shall this warranty cover the quality of transmission and reception of transceivers mounted in vehicles or vessels that have not been sufficiently electrically suppressed.

Should any fault due to bad design, workmanship or materials be proven at any time within the warranty period, the Seller will rectify such fault free of charge provided that the equipment is returned, freight paid, to Barrett Communications Pty Ltd head office or to an authorised service centre. The repaired or replaced product will remain covered under and throughout the term of the original warranty period up to its expiration. No repair or replacement will extend the warranty term past the original thirty-six (36) month anniversary of the original date of shipment from the Seller.

Firmware and software (pre-installed, stand-alone or provided as an update), hereafter referred to as 'Software', is guaranteed to perform acceptably within the specifications provided by the Seller, provided that the Software is within the warranty period.

Should Software not perform acceptably, the Seller will use all commercially reasonable efforts to correct such nonconformity as reported to the Seller directly or via a support representative. The Seller is not obliged to update Software under warranty if the nonconformity is caused by a) the use or operation of the Software in an environment other than intended or recommended by the Seller in relevant documentation, or b) modifications made to the Software not authorised or undertaken by the Seller or a representative of said Seller.

Subject to the matters set out in this warranty, no liability, expressed or implied is accepted for any consequential loss, damage or injury arising as a

result of a fault in the equipment and, all expressed or implied warranties as to quality or fitness for any purpose are hereby excluded.

This warranty does not extend to products supplied by the Seller which are not designed or manufactured by it. The Seller will however make every endeavour to ensure that the purchaser receives full benefit on any warranty given by the original equipment manufacturer.

This warranty is restricted to the original purchaser except where the original purchaser is a reseller authorised by the Seller who has purchased for the purpose of resale, warranty shall be extended to the reseller's customer.

Contact Details

Our customer / dealer technical support department can be contacted via land mail, email, telephone or via support ticket on the technical support web page.

<https://www.barrettcommunications.com.au/support/>

Barrett Communications Pty Ltd Head Office:

PO Box 1214, Bibra Lake WA 6965 AUSTRALIA

Toll Free Tel: 1800 999 580 (Within Australia)

Tel: +618 9434 1700

Fax: +618 9418 6757

email: support@barrettcommunications.com.au

Telephone support from the Australian office is available from 7:30 am to 4:00 pm local time Monday to Friday.

Barrett Communications – Europe:

Unit 9, Fulcrum 2 Victory Park, Solent Way,
Whiteley Hampshire PO15 7FN United Kingdom

Tel: +44 (0) 1489 880 332

Fax: +44 (0) 1489 565 422

email: support@barrettcommunications.co.uk

Telephone support from the UK office is available from 8:30 am to 5:00 pm local time Monday to Friday.

Barrett Communications Corporation USA:

90 Office Parkway

Pittsford, N.Y. 14534

Tel: +1 585 582 6134

E-Mail: support@barrettusa.com

Telephone support from the USA support office is available from 8:30 am to 5:00 pm local time Monday to Friday.

Head Office

Barrett Communications Pty Ltd
47 Discovery Drive, Bibra Lake, WA 6163 Australia
Tel: +61 8 9434 1700 Fax: +61 8 9418 6757
Email: info@barrettcommunications.com.au
www.barrettcommunications.com.au

Europe

Barrett Communications - Europe
Unit 9, Fulcrum 2, Solent Way, Whiteley, Hampshire, PO15 7FN United Kingdom
Tel: +44 (0) 1489 880 332 Fax: +44 (0) 1489 565 422
Email: uksales@barrettcommunications.co.uk

USA

Barrett Communications USA LLC
90 Office Parkway, Pittsford, NY 14534 United States of America
Tel: +1 585 582 6134
Email: sales@barrettusa.com